

INTERNATIONAL STANDARD



Display lighting unit – Part 1-2: Terminology and letter symbols



THIS PUBLICATION IS COPYRIGHT PROTECTED
Copyright © 2016 IEC, Geneva, Switzerland

All rights reserved. Unless otherwise specified, no part of this publication may be reproduced or utilized in any form or by any means, electronic or mechanical, including photocopying and microfilm, without permission in writing from either IEC or IEC's member National Committee in the country of the requester. If you have any questions about IEC copyright or have an enquiry about obtaining additional rights to this publication, please contact the address below or your local IEC member National Committee for further information.

IEC Central Office
3, rue de Varembe
CH-1211 Geneva 20
Switzerland

Tel.: +41 22 919 02 11
Fax: +41 22 919 03 00
info@iec.ch
www.iec.ch

About the IEC

The International Electrotechnical Commission (IEC) is the leading global organization that prepares and publishes International Standards for all electrical, electronic and related technologies.

About IEC publications

The technical content of IEC publications is kept under constant review by the IEC. Please make sure that you have the latest edition, a corrigenda or an amendment might have been published.

IEC Catalogue - webstore.iec.ch/catalogue

The stand-alone application for consulting the entire bibliographical information on IEC International Standards, Technical Specifications, Technical Reports and other documents. Available for PC, Mac OS, Android Tablets and iPad.

IEC publications search - www.iec.ch/searchpub

The advanced search enables to find IEC publications by a variety of criteria (reference number, text, technical committee,...). It also gives information on projects, replaced and withdrawn publications.

IEC Just Published - webstore.iec.ch/justpublished

Stay up to date on all new IEC publications. Just Published details all new publications released. Available online and also once a month by email.

Electropedia - www.electropedia.org

The world's leading online dictionary of electronic and electrical terms containing 20 000 terms and definitions in English and French, with equivalent terms in 15 additional languages. Also known as the International Electrotechnical Vocabulary (IEV) online.

IEC Glossary - std.iec.ch/glossary

65 000 electrotechnical terminology entries in English and French extracted from the Terms and Definitions clause of IEC publications issued since 2002. Some entries have been collected from earlier publications of IEC TC 37, 77, 86 and CISPR.

IEC Customer Service Centre - webstore.iec.ch/csc

If you wish to give us your feedback on this publication or need further assistance, please contact the Customer Service Centre: csc@iec.ch.



IEC 62595-1-2

Edition 2.0 2016-02

INTERNATIONAL STANDARD



Display lighting unit – Part 1-2: Terminology and letter symbols

INTERNATIONAL
ELECTROTECHNICAL
COMMISSION

ICS 31.120; 31.260

ISBN 978-2-8322-3170-8

Warning! Make sure that you obtained this publication from an authorized distributor.

CONTENTS

| | |
|---|----|
| FOREWORD..... | 3 |
| 1 Scope..... | 5 |
| 2 Normative references..... | 5 |
| 3 Terms and definitions | 5 |
| 3.1 Classification of terms | 5 |
| 3.2 Fundamental terms | 5 |
| 3.3 Terms related to passive optical components..... | 9 |
| 3.4 Terms related to solid-state light sources..... | 13 |
| 3.4.1 Light-emitting diode (LED)..... | 13 |
| 3.4.2 LED light bar..... | 14 |
| 3.5 Terms related to frontlight units | 15 |
| 3.6 Terms related to performances and specifications..... | 16 |
| 3.7 Terms related to backlight dimming | 18 |
| 4 Letter symbols (quantity symbols / unit symbols)..... | 20 |
| Annex A (informative) Supplementary figures | 21 |
| Figure A.1 – Backlighting concept for transmissive and transfective LCDs..... | 21 |
| Figure A.2 – Examples of edge-lit backlight units..... | 21 |
| Figure A.3 – Example of a direct-lit backlight unit | 22 |
| Figure A.4 – Visual definition of the terms related to passive optical components such as bezel and case..... | 22 |
| Figure A.5 – Luminance uniformity on a backlight unit | 23 |
| Figure A.6 – Polar coordinate system for evaluation of the angular luminance distribution..... | 23 |
| Figure A.7 – Angular luminance on a backlight unit..... | 24 |
| Figure A.8 – Examples of spectral power distribution of a display lighting unit..... | 24 |
| Figure A.9 – Incoherent light spread function for evaluation of optical characteristics of a block in a block-wise dynamic backlight unit | 24 |
| Figure A.10 – Light spread functions of three BLUs with different optical structures..... | 25 |
| Figure A.11 – Checkerboard pattern for evaluation of the luminance uniformity in a BLU | 26 |
| Table 1 – Letter symbols (quantity symbols / unit symbols)..... | 20 |

INTERNATIONAL ELECTROTECHNICAL COMMISSION

DISPLAY LIGHTING UNIT –

Part 1-2: Terminology and letter symbols

FOREWORD

- 1) The International Electrotechnical Commission (IEC) is a worldwide organization for standardization comprising all national electrotechnical committees (IEC National Committees). The object of IEC is to promote international co-operation on all questions concerning standardization in the electrical and electronic fields. To this end and in addition to other activities, IEC publishes International Standards, Technical Specifications, Technical Reports, Publicly Available Specifications (PAS) and Guides (hereafter referred to as “IEC Publication(s)”). Their preparation is entrusted to technical committees; any IEC National Committee interested in the subject dealt with may participate in this preparatory work. International, governmental and non-governmental organizations liaising with the IEC also participate in this preparation. IEC collaborates closely with the International Organization for Standardization (ISO) in accordance with conditions determined by agreement between the two organizations.
- 2) The formal decisions or agreements of IEC on technical matters express, as nearly as possible, an international consensus of opinion on the relevant subjects since each technical committee has representation from all interested IEC National Committees.
- 3) IEC Publications have the form of recommendations for international use and are accepted by IEC National Committees in that sense. While all reasonable efforts are made to ensure that the technical content of IEC Publications is accurate, IEC cannot be held responsible for the way in which they are used or for any misinterpretation by any end user.
- 4) In order to promote international uniformity, IEC National Committees undertake to apply IEC Publications transparently to the maximum extent possible in their national and regional publications. Any divergence between any IEC Publication and the corresponding national or regional publication shall be clearly indicated in the latter.
- 5) IEC itself does not provide any attestation of conformity. Independent certification bodies provide conformity assessment services and, in some areas, access to IEC marks of conformity. IEC is not responsible for any services carried out by independent certification bodies.
- 6) All users should ensure that they have the latest edition of this publication.
- 7) No liability shall attach to IEC or its directors, employees, servants or agents including individual experts and members of its technical committees and IEC National Committees for any personal injury, property damage or other damage of any nature whatsoever, whether direct or indirect, or for costs (including legal fees) and expenses arising out of the publication, use of, or reliance upon, this IEC Publication or any other IEC Publications.
- 8) Attention is drawn to the Normative references cited in this publication. Use of the referenced publications is indispensable for the correct application of this publication.
- 9) Attention is drawn to the possibility that some of the elements of this IEC Publication may be the subject of patent rights. IEC shall not be held responsible for identifying any or all such patent rights.

International Standard IEC 62595-1-2 has been prepared by IEC technical committee 110: Electronic display devices.

This second edition cancels and replaces the first edition published in 2011. This edition constitutes a technical revision.

This edition includes the following significant technical changes with respect to the previous edition:

- a) change in the series title in order to handle frontlight units;
- b) new terms are added considering recent advances in display lighting unit (DLU) technology;
- c) some of terms and definitions are corrected and revised, particularly to be consistent with IEC 62595-2;
- d) some of the terms and definitions are corrected and revised, particularly to be consistent with IEC 60050 policy;

- e) clause structure is rectified for categorizing terms correctly;
- f) some of figures in Annex A are added or revised for better understanding.

The text of this standard is based on the following documents:

| FDIS | Report on voting |
|--------------|------------------|
| 110/720/FDIS | 110/734/RVD |

Full information on the voting for the approval of this standard can be found in the report on voting indicated in the above table.

This publication has been drafted in accordance with the ISO/IEC Directives, Part 2.

A list of all the parts in the IEC 62595 series, under the general title *Display lighting unit*, can be found on the IEC website.

Future standards in this series will carry the new general title as cited above. Titles of existing standards in this series will be updated at the time of the next edition.

The committee has decided that the contents of this publication will remain unchanged until the stability date indicated on the IEC website under "<http://webstore.iec.ch>" in the data related to the specific publication. At this date, the publication will be

- reconfirmed,
- withdrawn,
- replaced by a revised edition, or
- amended.

A bilingual version of this publication may be issued at a later date.

IMPORTANT – The 'colour inside' logo on the cover page of this publication indicates that it contains colours which are considered to be useful for the correct understanding of its contents. Users should therefore print this document using a colour printer.

DISPLAY LIGHTING UNIT –

Part 1-2: Terminology and letter symbols

1 Scope

This part of IEC 62595 gives the preferred terms, their definitions and symbols for display lighting units (DLUs) such as backlight units (BLUs) of transmissive and transreflective LCDs, and frontlight units (FLUs) of reflective LCDs and electronic paper (E-paper) displays, with the object of using the same terminology when publications are prepared in different countries.

2 Normative references

The following documents, in whole or in part, are normatively referenced in this document and are indispensable for its application. For dated references, only the edition cited applies. For undated references, the latest edition of the referenced document (including any amendments) applies.

IEC 60050-845, *International Electrotechnical Vocabulary – Part 845: Lighting*

3 Terms and definitions

For the purposes of this document, the terms and definitions given in IEC 60050-845¹ as well as the following apply.

3.1 Classification of terms

Terms for display lighting units (DLUs), such as backlight units (BLUs) and frontlight units (FLUs) are classified as follows:

- a) fundamental terms related to display lighting units (3.2);
- b) terms related to passive optical components used in display lighting units (3.3);
- c) terms related to solid-state light sources used in display lighting units (3.4);
- d) terms related particularly to frontlight units (3.5);
- e) terms related to performances and specifications (3.6);
- f) terms related to backlight dimming (3.7).

The following definitions are applied for international standardization of the backlight units.

3.2 Fundamental terms

3.2.1

display lighting unit

DLU

lighting unit for recognition of the displayed images on a non-emissive electronic display device

¹ Identical to CIE 17.4.

3.2.2**backlight unit****BLU**

display lighting unit that is set at the rear of a non-emissive electronic display device such as a transmissive or transfective liquid crystal (LC) device

Note 1 to entry: For an example, see Figure A.1.

3.2.3**edge-lit backlight unit****side-lit backlight unit****edge-light backlight unit****side-light backlight unit**

backlight unit in which an optically transparent medium (typically light-guide plate) is used in proximity with the light source(s) for introducing the light into the medium from one or several sides of the medium to illuminate an LC device

Note 1 to entry: For an example, see Figure A.2.

3.2.4**direct-lit backlight unit****direct-view backlight unit**

backlight unit in which a light chamber is used in combination with light source(s) that are mounted inside the chamber, for illuminating a transmissive LC device mounted on the light chamber for the purpose of image recognition

Note 1 to entry: For an example, see Figure A.3.

3.2.5**side-driven direct-lit backlight unit**

backlight unit in which a light chamber is used in combination with light sources(s) that are mounted on the inner sides of the light chamber for illuminating a panel mounted on the light chamber for the purpose of image recognition

3.2.6**static backlight unit**

single or integrated flat illumination system that operates with direct or alternative current and possesses a unique optical characteristic

3.2.7**dynamic backlight unit**

single or integrated illumination units that possess a unique electro-optical characteristic which is synchronized with the local picture and its contents displayed on an LC device

3.2.8**blinking backlight unit**

backlight unit that is periodically switched on and off for synchronically illuminating an LC device

3.2.9**scanning backlight unit**

backlight unit that is divided optically or spatially into several line blocks and is periodically switched on and off, block by block, for synchronous illumination of an LC device

3.2.10**directional backlight unit****D-BLU**

backlight unit that collimates emergent light into an arbitrary solid angle or directs the collimated emergent light toward a spatial zone or surface on the back side of the LC device

3.2.11**multi-directional backlight unit**

backlight unit in which the light sources (LEDs or LDs) are spatially mounted in an array around a micro- or submicro-featured (structured) light-guide plate (LGP) or light-guide film (LGF), for sequentially switching to create spatially and/or angularly directed light for rendering a 3D image on the LC device

Note 1 to entry: LED and LD are defined later.

3.2.12**scanning directional backlight unit
scanning D-BLU**

D-BLU that illuminates continuously or distinctively a wide solid angle and/or an area in front of the backlight unit, i.e. the backside of the LC device, by consecutively switching (on and off) the spatially distributed light source array on the side surfaces of the light-guide plate (LGP)

3.2.13**spatio-temporal switching backlight unit**

backlight unit that is divided optically or spatially into several horizontal blocks and periodically switched on and off from top to bottom under a time table for illuminating or flashing red, green, or blue light in synchronization with a field-sequential colour LC device with or without micro colour filters

3.2.14**field alternate LCD backlight unit
top and bottom flashing**

backlight unit that includes a single light-guide plate (single or spatially divided into top and bottom) with distinctive upper and lower light source groups for illuminating an LC device in which an image is divided into top and bottom parts that are displayed alternately on the LC device in order to compensate the slow response time of the LC device

3.2.15**field alternate LCD backlight unit
left and right alternate flashing**

backlight unit that includes a single light-guide plate (LGP) or stacked LGPs for illuminating an LC device in which an image is divided into a left and right image in which the two images are oriented in different directions and where the left and right images are displayed alternately on the LC device in order to create a 3D image display

3.2.16**single-side light emission backlight unit**

backlight unit that emits light from a front surface or rear surface (i.e. from a single side) for illuminating a single LC device

3.2.17**double-sides light emission backlight unit**

backlight unit that emits light from both the front and the rear surface for illuminating two LC devices

3.2.18**segmented backlight unit**

backlight unit that is divided into blocks or segments in two dimensions for synchronization with an LC device for illuminating individually each block or segment of the LC device

3.2.19**quasi-monochromatic backlight unit**

backlight unit that uses a single quasi-monochromatic light source for illuminating a transmissive LC device

3.2.20**multi-colour backlight unit**

backlight unit that consists of multiple primaries or multiple quasi-monochromatic light sources for illuminating an LC device for displaying a wide colour gamut that is used for a printer, professional design monitor or field alternative wide colour gamut LC device

3.2.21**portability enhanced backlight unit**

backlight unit the optical components of which are thin and lightweight to enhance portability

3.2.22**corner driven backlight unit**

edge-lit backlight unit in which the light is driven from one or several flattened corners of a rectangular light-guide plate using single or multiple light sources

3.2.23**stack backlight unit**

backlight unit in which more than one single light control medium or light-guide plate is used in stack form in the structure for light direction controlling or light shaping

3.2.24**colour reproduction backlight unit**

backlight unit that uses light sources of three or more primaries in order to produce a wide colour gamut on an LC device

3.2.25**light-emitting diode backlight unit****LED backlight unit**

backlight unit that uses LEDs as light sources

3.2.26**laser backlight unit**

backlight unit that uses laser(s) as light source(s)

3.2.27**laser diode backlight unit****LD backlight unit**

laser backlight unit that uses LD(s) as light source(s)

3.2.28**RG-white backlight unit**

backlight unit that uses light sources such as LEDs or LDs that emit light of red, green and white (i.e. RG-white) colours

3.2.29**RGW backlight unit**

backlight unit that uses distinct red, green and pseudo-white LEDs or LDs as light sources

3.2.30**three primaries (R,G,B) backlight unit**

backlight unit that uses three primary colours of red, green, and blue quasi-monochromatic LEDs or monochromatic LDs as light sources

3.2.31**six primaries (R₁,G₁,B₁,R₂,G₂,B₂) backlight unit**

backlight unit employing two groups of red, green and blue light sources for illuminating an LC device which is used for reproduction of colours of photographs

3.2.32**single-flash backlight unit**

backlight unit that flashes periodically and is synchronized with an LC device for the purpose of inserting a black or grey frame in order to enhance the moving image quality on the display

3.2.33**multi-flash backlight unit**

spatially linear segmented backlight unit for scanning or field-sequential colour display that flashes periodically and is synchronized with the LC device for the purpose of inserting colour fields (displayed image with single colour) or black or grey fields in order to enhance the displayed image quality on the display or spatially mix the colours for displaying coloured images

3.2.34**multi-primary colours backlight unit**

backlight unit that employs multiple LEDs or LDs which have different peak wavelengths of primaries

3.2.35**tandem backlight unit**

backlight unit that is an integration of multiple distinct and overlapped edge-lit backlight units

3.2.36**quantum dot backlight unit****QD backlight unit**

edge-lit or direct-lit backlight unit in which blue light source(s) such as LEDs or LDs stimulate the film set on the backlight unit or a glass tube filled with quantum dot materials to create white light with three primaries spectra on the backlight unit

3.3 Terms related to passive optical components**3.3.1****light-guide plate****LGP**

optically transparent medium with thick and solid structure that is generally employed in an edge-lit backlight unit for forming the required light distribution spatially for transmissive or transmissive LC devices

Note 1 to entry: For an example, see Figure A.4.

3.3.2**light-guide film****LGF**

optically transparent medium with thin and flexible structure that is employed instead of light-guide plate (LGP) in an edge-lit backlight unit for forming the required light distribution spatially for a transmissive or transmissive LC device

3.3.3**functional light-guide plate****functional light-guide film**

optically transparent medium characterized by optical micro- or submicro-structures for shaping spatially or angularly the required light distribution in an edge-lit backlight unit for illuminating a transmissive or transmissive LC device

3.3.4**slab light-guide plate****slab light-guide film**

light-guide plate or light-guide film that has a slab geometrical shape

3.3.5**wedge light-guide plate****wedge light-guide film**

light-guide plate or light-guide film with a wedge shape (single or double wedge) introducing the light from the thicker side

3.3.6**inverted wedge light-guide plate****inverted wedge light-guide film**

light-guide plate or light-guide film with a single or double wedge in which the light is introduced from the thinner side

3.3.7**double-side functional light-guide plate****double-side functional light-guide film**

light-guide plate or light-guide film structured with micro- or submicro-structure(s) on the rear and front surfaces for light shaping on the backlight unit

3.3.8**single-side functional light-guide plate****single-side functional light-guide film**

light-guide plate or light-guide film structured with light reflecting micro-reflectors or light deflecting micro-deflectors arrays on the rear or front surface for shaping and extracting the propagating light

3.3.9**diffusing light-guide plate****diffusing light-guide film**

light-guide plate or light-guide film structured with light diffusing micro-structures on its rear and front or both surfaces for light shaping or the resin of which is filled with diffusing materials such as beads

3.3.10**reflective light-guide plate****reflective light-guide film**

light-guide plate or light-guide film structured with optical micro-reflectors on the rear surface for extracting light from the front surface

3.3.11**deflective light-guide plate****deflective light-guide film**

light-guide plate or light-guide film structured with optical micro-deflective elements on the front surface for the purpose of deflecting the emergent light rays from the front surface of the light-guide plate or light-guide film

3.3.12**dispersive light-guide plate****dispersive light-guide film**

light-guide plate or light-guide film structured with micro-optical elements for dispersing the emergent light on the light-guide plate or light-guide film

3.3.13**polarizing light-guide plate****polarizing light-guide film**

light-guide plate or film with micro- or submicro-structures for generating polarized light on its front surface

3.3.14**diffuser film**

optical film that functions as light-diffusing component in the backlight unit structure

Note 1 to entry: For an example, see Figure A.4.

3.3.15**prism film**

optical film that possesses discrete prism lines or continuous prism lines with triangular prismatic cross-section structures for collimating or deflecting (on its surface) the rays that are incident on the rear surface of the film

3.3.16**circular prism film**

film that possesses a geometrically circular prism structure with a triangular prismatic cross section for collimating and deflecting azimuthally the incident light rays striking the prism's inner surfaces

3.3.17**luminance enhancing film****brightness enhancing film**

light-collimating film in which the incident light on its rear surface is collimated on its front surface resulting in luminance or brightness enhancement

Note 1 to entry: For an example, see Figure A.4.

3.3.18**inverted prism film**

optical film with an array of line prisms in which the tips of the prisms are directed towards the light-guide plate in a backlight unit structure

3.3.19**total-internal-reflection film****TIR film**

optical film (such as an inverted prism film) that has a light-ray deflecting function based on the total internal reflection

3.3.20**reflector film**

film for reflecting back the light that emerges from the surfaces next to the front surface of the light-guide plate or light-guide film

3.3.21**light-collimating film**

optical film that collimates light incident on its rear surface on its front surface

3.3.22**quantum dot film****QD film**

film that sandwiches the quantum dot layer to be used on the backlight unit and stimulated by blue emission light sources such as LEDs or LDs

3.3.23**micro-deflector element**

optical micro-structure with light ray deflection function structured on the front or rear surface of a functional light-guide plate or light-guide film

3.3.24**micro-reflector element****submicro-reflector element**

optical micro- or submicro-structure with light ray reflection function structured on the front or rear or both surfaces of the functional light-guide plate or light-guide film

3.3.25**micro-diffusive element****submicro-diffusive element**

optical micro- or submicro-structure with a light ray dispersing function structured on the front or rear or both surfaces of the functional light-guide plate or light-guide film

3.3.26**specular light reflector film**

light reflector film coated with metal (such as silver, aluminium) or structured with multiple optical layers for reflecting incident light without diffusion of the incident light

3.3.27**partially specular light reflector**

reflector film with specular reflection characteristic and partially light diffusing characteristic

3.3.28**light-diffusing reflector**

optical film that diffuses the incident light and generates a homogeneous or non-homogeneous light distribution

3.3.29**light-source reflector**

piece of metal or paper with a highly reflective surface that is used for introducing or re-reflecting light that travels in other directions rather than towards the light control medium in a backlight unit

3.3.30**light-guide reflector**

piece of metal or paper with a highly reflective surface that is used on the rear or side surfaces of a light-guide plate or light-guide film for reflecting back the light emerging from the rear surface or side surfaces of the light guide-plate or light-guide film

3.3.31**light cone**

solid angle into which the light radiates from the front surface of a backlight unit or light-guide plate

3.3.32**block**

<backlight unit> segment of a backlight unit which is divided two-dimensionally for synchronization with an LC device for the purpose of local dimming

3.3.33**partition**

<backlight unit> piece of metal, coated paper or light diffusing reflector for optically isolating the segments of a one- or two-dimensionally divided backlight unit

3.3.34**addressed block**

segment of spatially divided backlight unit for local dimming that cooperates with the locally addressed LC device for improving image quality and power saving

3.3.35**flashing block**

segment of a spatially divided backlight unit that flashes in response to written data of a local segment of an LC device

3.3.36**backlight cavity**

light-controlling cavity structured by optical micro- or submicro-features or surrounded by optically micro- or submicro-structured films for directing light toward the rear of an LC device

3.3.37**light chamber**

light box the inner side of which is optically characterized for light shaping and extracting and used in a direct-lit backlight unit

3.3.38**bezel**

<backlight unit> geometrically shaped metal or non-metal front frame for mechanically fixing together an LC device and a backlight unit

Note 1 to entry: For an example, see Figure A.4.

3.3.39**case**

<backlight unit> housing of the backlight unit

Note 1 to entry: For an example, see Figure A.4.

3.3.40**flexible printed circuit****FPC**

<backlight unit> piece of flexible material (such as polyimide) that has a printed circuit on its surface for driving electrically the light sources and complementary electrical devices in a backlight unit

Note 1 to entry: For an example, see Figure A.4.

3.3.41**metal core printed circuit board****MCPCB**

<backlight unit> solid metal board on which an electric circuit has been printed for mounting solid-state light sources and for use as a heat sink in the backlight unit structure

Note 1 to entry: For an example, see Figure A.4.

3.4 Terms related to solid-state light sources**3.4.1 Light-emitting diode (LED)****3.4.1.1****pseudo-white LED**

solid-state light source that has an LED die (chip) emitting blue light and typically YAG (yttrium aluminium garnet) phosphor for converting a part of the blue light into yellow colour for generating white light based on complementary colour mixing

3.4.1.2**RGB LED**

combination of solid-state quasi-monochromatic light sources with primary colours

Note 1 to entry: RGB LED can also be defined as a set of LED dies (chips) with quasi-monochromatic light of primaries that are packed together to mix additively and obtain a white light at a predefined point

3.4.1.3**ultra-violet stimulated white LED****UV-white LED**

solid-state light source with an LED die (chip) emitting light in the ultraviolet wavelength range of ultra violet that stimulates a combination of blue, green and red phosphors to create light having white colour

3.4.1.4**near UV stimulated white LED****NUV-white LED**

solid-state white light source with an LED die (chip) emitting light in the near ultraviolet wavelength range (e.g. 380 nm to 410 nm) and a combination of blue, green and red phosphors that are stimulated by the light of the LED die

3.4.1.5**RG-white LED**

solid-state white light source with an LED die (chip) emitting blue light that stimulates red (R) and green (G) phosphors which are added to the cavity of the LED package

3.4.1.6**quasi-monochromatic LED**

LED die emitting light at a dominant wavelength and possessing a bandwidth

3.4.2 LED light bar**3.4.2.1****LED light bar**

strip light source in which multiple LEDs are mounted along the length of the strip to create a linearly uniform distribution of illuminance in the backlight unit

Note 1 to entry: For an example, see Figure A.4

3.4.2.2**side-view light bar**

light bar that employs LEDs with a side-fire radiation pattern

3.4.2.3**top-view light bar**

light bar that employs LEDs with a top-fire radiation pattern

3.4.2.4**bulk-coupling light bar**

light bar that employs omni-directional LEDs in which the light from the LEDs is coupled into the body of the light-guide plate or light-guide film

3.4.2.5**omni-directional light source bar**

light bar that employs LEDs with an omni-directional radiation pattern

3.4.2.6**uniformly coloured light bar**

light bar that has a uniform chromaticity

3.4.2.7**light bar tolerance**

predefined tolerance in the illuminance of the light bar at a predefined distance from the light bar

3.4.2.8**light bar spatial luminance distribution**

spatial luminance distribution on the light bar or at a pre-defined direction and distance from the light bar

3.4.2.9**light bar angular luminance distribution**

angular luminance distribution around the light bar in a pre-defined direction and angle which are defined in the polar coordinate system

3.4.2.10**quantum dot tube****QD tube****quantum dot bar****QD bar**

glass tube or bar with quantum dots that is used in front of an array of blue LED(s) as stimulation source to generate a white light

3.4.2.11**quantum dot tube spatial luminance distribution****quantum dot bar spatial luminance distribution**

spatial luminance distribution of a stimulated quantum dot tube or quantum dot bar defined at a distance in front of the quantum dot tube or bar

3.4.2.12**quantum dot tube spatial luminance uniformity****quantum dot bar spatial luminance uniformity**

spatial luminance uniformity of a quantum dot tube or quantum dot bar stimulated by blue-light-emitting LED(s) or LD(s)

3.4.2.13**quantum dot tube angular luminance distribution****quantum dot bar angular luminance distribution**

angular luminance distribution of blue-light-stimulated quantum dot tube (or quantum dot bar) along the tube (or bar) or perpendicular to the tube (or bar) when stimulated by an array of blue LED(s) or LD(s)

3.5 Terms related to frontlight units**3.5.1****frontlight unit****FLU**

display lighting unit that is set on the front side of non-emissive electronic display devices such as a reflective or transfective (partially transmissive or partially reflective) LC device or electronic paper display

3.5.2**prismatic light-guide plate****prismatic light-guide film**

transparent optical medium for direction controlling and shaping the light by the prismatic micro-structures that are fabricated on the front or rear or both the surfaces of the medium

3.5.3**two-surface micro-prism reflector**

unilateral or bilateral microprism with two light-reflecting surfaces usually fabricated on the light-guide plate or light-guide film or stick light

3.5.4**three-surface micro-prism reflector**

micro-prismatic structure with three light reflecting surfaces fabricated on light collimating light-guide plate or light-guide film or stick light

3.5.5**stick light****stick lightguide**

straight and slender lightguide (transparent optical medium with any geometrical cross-section) with an array of micro-structures for transforming a point source into a uniform line source to be used in a backlight unit or a frontlight unit

3.5.6**stick light reflector****stick light-guide reflector**

piece of metal or paper with a highly reflecting surface for covering the longitudinal sides (beside the light emerging surface) of the stick light

3.5.7**stick light directivity****stick light-guide directivity**

angular luminance distribution of a stick light used in a backlight unit or a frontlight unit

3.5.8**anti-reflection coating**

single or multi coating (on the light-guide plate or light-guide film of a frontlight unit) for reducing undesired reflected light that results in the apparition of ghost images when the frontlight unit is integrated to the reflective display

3.5.9**ghost image**

result of undesired reflected light in the prismatic light-guide plate or light-guide film used in a frontlight unit

3.6 Terms related to performances and specifications**3.6.1****luminance uniformity****spatial luminance distribution**

distribution of luminance measured at predefined point(s) on the display lighting unit

Note 1 to entry: For an example, see Figure A.5.

3.6.2**luminance evaluation point**

infinitesimal area on a display lighting unit that is measured and used for evaluation of the luminance and luminance uniformity, usually defined as a 25-point measurement

3.6.3**angular luminance distribution**

luminance distribution of an illuminating flat area or display lighting unit that is measured at zenith angles of 0° to 90° and azimuthal angles of 0° to 360°

Note 1 to entry: For an example, see the polar coordinates shown in Figure A.6.

3.6.4**angular luminance variation**

variation of luminance with zenith (θ) or azimuth (φ) angles on the illuminating surface of a display lighting unit, that is, $L_v(\theta, \varphi, x_i, y_i, z_i)$, where the coordinates of an arbitrary point are at (x_i, y_i, z_i) on the backlight unit and (θ, φ) are the light cone extends with respect to the centre axis deviated from the surface normal of the display lighting unit

Note 1 to entry: For an example, see Figure A.7.

3.6.5**angular luminance uniformity**

angular luminance variation of a point on a display lighting unit with zenith angle (θ)

3.6.6**colour definition point**

point for defining chromaticity on a display lighting unit with pseudo-white light sources or distinct different monochromatic light sources

3.6.7**colour uniformity**

variation of colour on a display lighting unit that is defined using a chromaticity difference between the predefined points

3.6.8**colour mixing**

colour additive process in a display lighting unit for obtaining white colour at a predefined point

3.6.9**colour mixing area**

area for mixing additively different colours from quasi-monochromatic light sources in a display lighting unit in order to obtain a white point at a predefined point

3.6.10**angular colour uniformity**

uniformity of colour in a luminance distribution of a point on a display lighting unit, measured along the polar angle (zenith angle)

3.6.11**spectral dependence of angular luminance distribution**

angular luminance distribution of a point on a display lighting unit in which spectral radiation changes with polar (zenith) angle

3.6.12**colour shift**

change in colour on a predefined point on the display lighting unit

3.6.13**backlight gamma characteristic**

fidelity response characteristic of a spatially block-wise backlight unit to the spatial frequencies of the display image frame

3.6.14**optical signal-to-noise ratio****optical S/N ratio**

<display lighting unit> ratio of desired luminance to un-desired luminance in pre-defined zenith and azimuth angles

3.6.15**ageing time**

<display lighting unit> period of time necessary to stabilize the output luminance of a display lighting unit

3.6.16**spectral power distribution** $S_{\text{DLU}}(\lambda)$

<display lighting unit> power spectrum per unit area, measured using a spectrometer or an optical spectrum analyser as the spectrum of light emerging from a unit area on a display lighting unit

Note 1 to entry: For an example, see Figure A.8.

3.6.17**incoherent light spread function****I-LSF**

<backlight unit> three-dimensional or two-dimensional spatial luminance profile of a single circularly symmetric infinitesimal point or block (having x-axis or y-axis symmetry) in a block-wise backlight unit illuminated by one or more incoherent light sources such as an LED or diffused light of an LD

3.6.18**block-wise incoherent light spread function**

<backlight unit> luminance profile of a block of a block-wise backlight unit illuminated by one or more incoherent light source(s) such as an LED or the diffused light of an LD

Note 1 to entry: For an example, see Figure A.9 and Figure A.10.

3.6.19**incoherent line spread function**

<backlight unit> luminance profile of a linear block of a block-wise backlight unit illuminated by an incoherent line light source, such as an LED or the diffused light of an LD line array

3.6.20**incoherent modulation transfer function****I-MTF****light transfer function****LTF**

<backlight unit> spatial frequency response of a backlight unit of a block-wise backlight unit in response to an incoherent illuminating light source such as an LED or the diffused light of an LD

3.6.21**monochromatic incoherent modulation transfer function****monochromatic incoherent MTF**

<backlight unit> modulation transfer function of a backlight unit in response to a quasi-monochromatic point light source such as an LED or the diffused light of an LD

Note 1 to entry: The monochromatic incoherent MTF is expressed in spatially modulated light versus spatial frequency (line pair per millimetre).

3.6.22**chromatic incoherent light spread function****chromatic incoherent LSF**

<backlight unit> incoherent light spread function of a backlight unit in response to a quasi-monochromatic point light source

3.7 Terms related to backlight dimming**3.7.1****adaptive dimming**

temporally low passed image of a local image of an LCD that is displayed on a backlight unit with several blocks for the purpose of image enhancement and power saving

3.7.2**zero-dimensional dimming****0-D dimming****global dimming**

manipulation of luminance on a backlight unit in response to a signal from the displayed image on an LCD that is used on the backlight unit

3.7.3**one-dimensional dimming****1-D dimming****line dimming**

manipulation of luminance over an area of a one-dimensionally (horizontally) divided backlight unit in response to the image that is going to be displayed on the LC device in the same area

3.7.4**local dimming****block dimming****two-dimensional dimming****2-D dimming**

manipulation of luminance over an area of a two-dimensionally (spatially) divided backlight unit in response to the image that is going to be displayed on the LC device at the same area

3.7.5**three-dimensional dimming****3-D dimming**

manipulation of the chromaticity over an area of a two dimensionally (spatially) divided backlight unit in response to the image that is going to be displayed on the LC device at the same area

3.7.6**high-dynamic range backlight unit**

spatially divided backlight unit that uses a temporally low passed image that is input to an LC device, to enhance the contrast of the displayed image on the display

3.7.7**backlight resolution**

number of blocks or segments in a local dimming type backlight unit that can display a low passed filtered image that is input to an LC device

3.7.8**optical noise**

<backlight unit> undesired light that leaks from a block to adjacent blocks in one- and two-dimensionally divided backlight units

3.7.9**block-wise optical signal-to-noise ratio****block-wise optical S/N ratio**

ratio of angular luminance of one or more adjacent blocks to that of the block under evaluation

Note 1 to entry: For an example, see Figure A.11.

3.7.10**block-wise optimum signal-to-noise ratio****block-wise optimum S/N ratio**

ratio of the optimum amount of light (to that of the leaked light) which is transmitted from a block to adjacent blocks for the purpose of smoothing and qualifying the front-of-screen on the display in a one- or two-dimensionally divided backlight unit to the amount of light on the segment or block under evaluation

Note 1 to entry: For an example, see Figure A.9.

3.7.11

crosstalk

<backlight unit> amount of light that leaks from a block to adjacent blocks or segments (optical noise) in a one- or two-dimensionally divided backlight unit, causing independently displayed block image degradation on the LC device

Note 1 to entry: For an example, see Figure A.11.

Note 2 to entry: The measurement of crosstalk is performed by applying a checkerboard pattern in which the on (white) and off (black) segments are created as shown in Figure A.11. The luminance on the centre of the off segment is measured by expanding the off segment pattern by 1 %.

4 Letter symbols (quantity symbols / unit symbols)

The letter symbols for DLUs are shown in Table 1.

Table 1 – Letter symbols (quantity symbols / unit symbols)

| | |
|--|---|
| Arbitrary luminance of a point | L_{vi} (cd/m ²) |
| Maximum luminance | L_{vM} (cd/m ²) |
| Minimum luminance | L_{vm} (cd/m ²) |
| Average luminance | L_{va} (cd/m ²) |
| Centre luminance | L_{vc} (cd/m ²) |
| Luminance uniformity | U (%) |
| Angular luminance variation | $L_v(x, y; \theta, \varphi)$ (cd/m ²) |
| Solid angle | Ω (sr) |
| Colour uniformity | $\Delta u'v'$ |
| Spectral power distribution of a display lighting unit | $S_{DLU}(\lambda)$ |
| LED forward driving current | I_F (mA) |

Annex A (informative)

Supplementary figures

Figures A.1 to A.11 provide examples of various terms defined in the text.

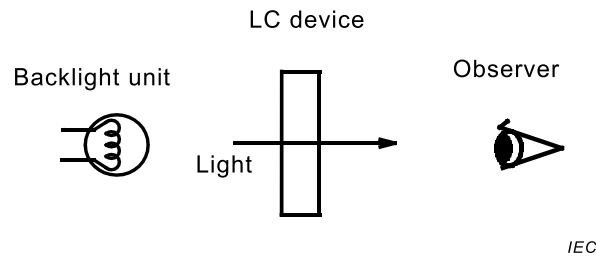
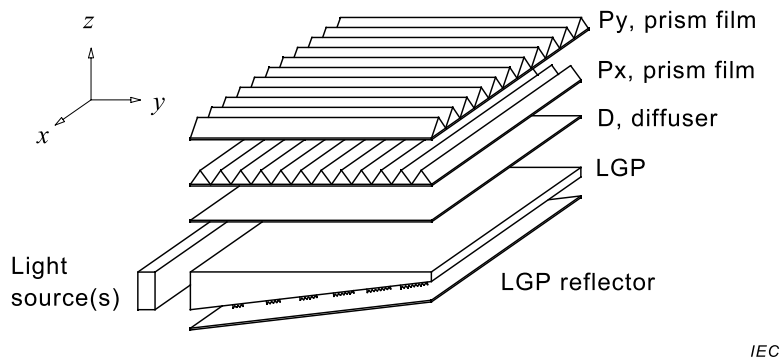
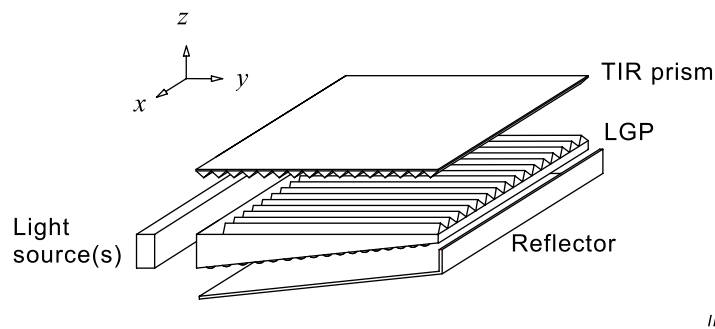

Figure A.1 – Backlighting concept for transmissive and transmissive LCDs



a) Conventional edge-lit backlight unit with arbitrary light sources



b) Edge-lit backlight unit with TIR prism (an inverted prism with TIR characteristics) and a functional light guide plate

Figure A.2 – Examples of edge-lit backlight units

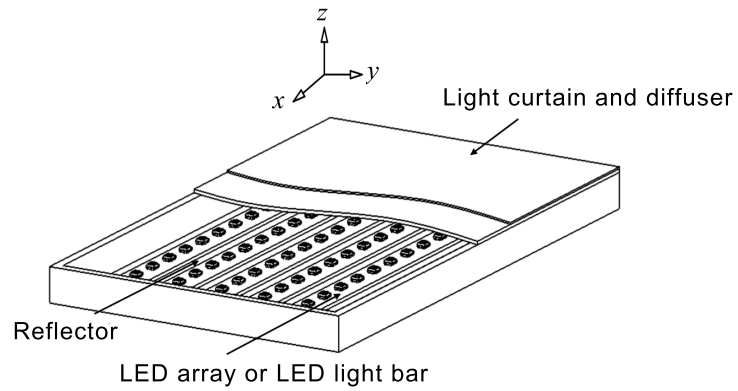

IEC

Figure A.3 – Example of a direct-lit backlight unit

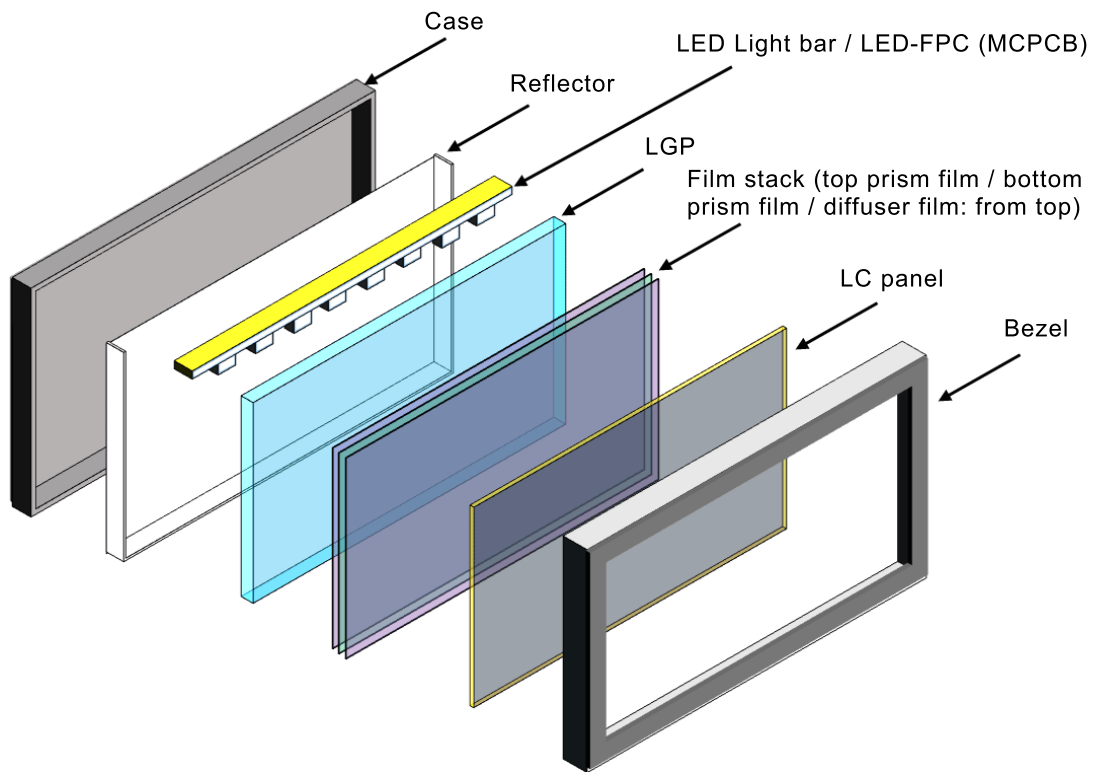

IEC

Figure A.4 – Visual definition of the terms related to passive optical components such as bezel and case

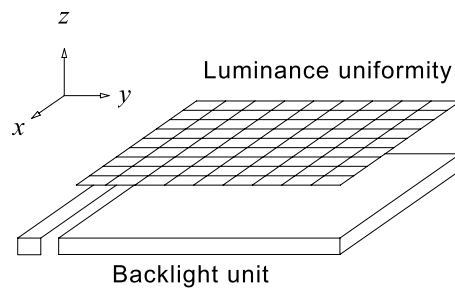

IEC

a) Backlight unit with highly uniform spatial luminance uniformity

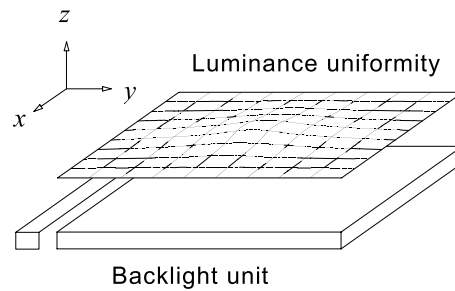

IEC

b) Backlight with a low profile Gaussian luminance uniformity

Figure A.5 – Luminance uniformity on a backlight unit

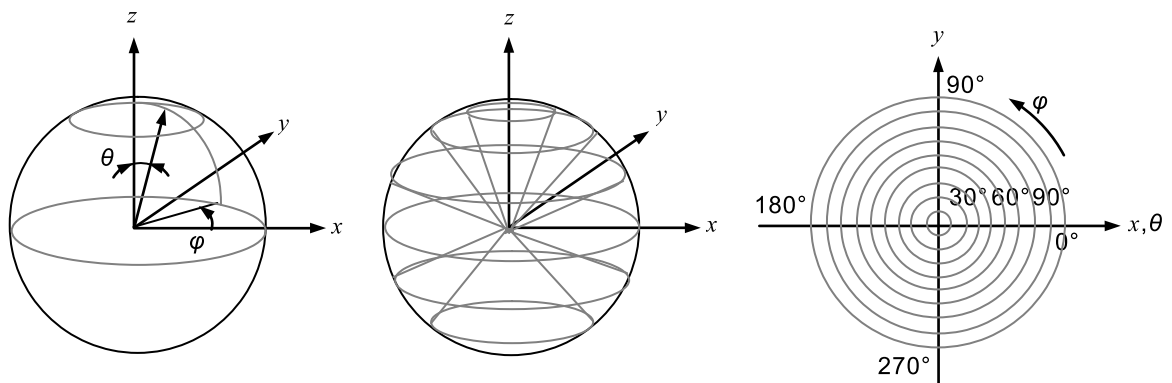

IEC

NOTE The angular luminance distribution of the backlight unit is evaluated in this coordinate system where φ is the azimuth angle (0° to 360°) and θ is the zenith angle (0° to 180°).

Figure A.6 – Polar coordinate system for evaluation of the angular luminance distribution

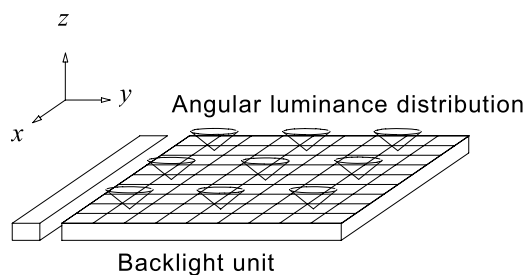

IEC

NOTE The angular luminance distribution is slightly different due to the propagating light distribution (along the y-axis) in the LGP, LGF or light shaping medium.

Figure A.7 – Angular luminance on a backlight unit

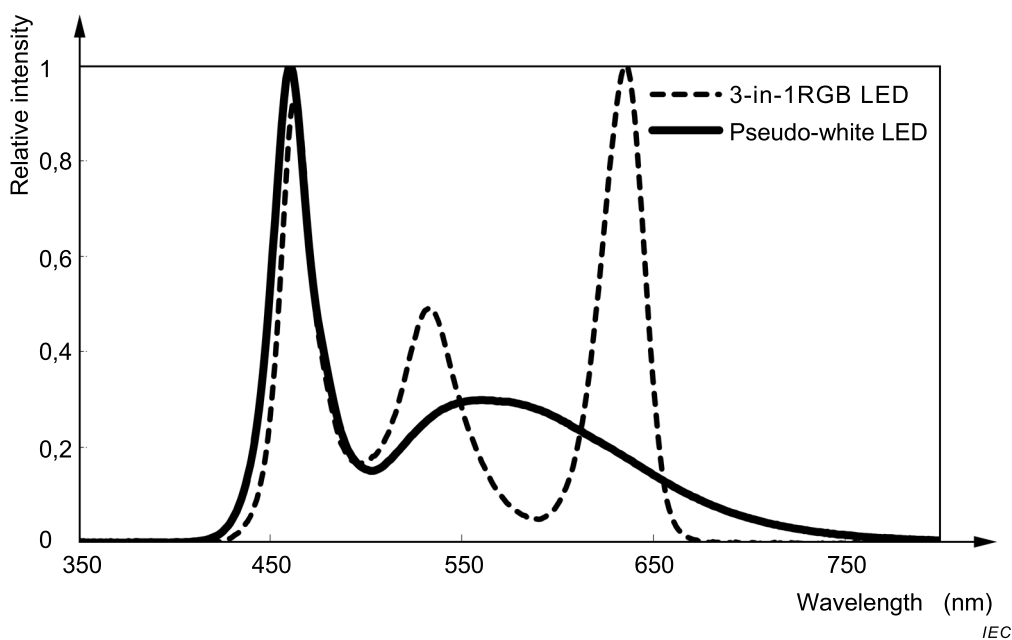

IEC

Solid line: BLU with pseudo-white LEDs.

Broken line: BLU with 3-in-1 RGB LEDs (R, G, B LED chips assembled in a single package cavity).

Figure A.8 – Examples of spectral power distribution of a display lighting unit

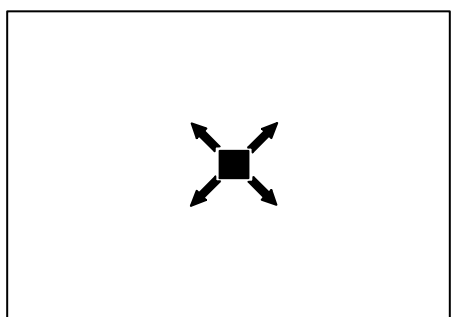

IEC

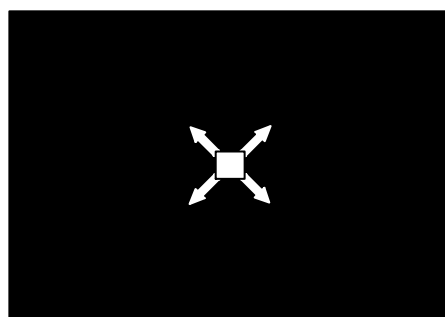

IEC

a) White segments are "ON" and the black segment (centre) is "OFF"

b) Black segments are "OFF" and the white segment (centre) is "ON"

NOTE The white and black blocks show the on and off conditions, applied to all blocks.

Figure A.9 – Incoherent light spread function for evaluation of optical characteristics of a block in a block-wise dynamic backlight unit

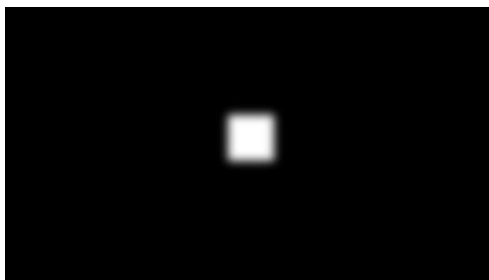

IEC

- a) Incoherent light spread function (with a narrow angular luminance cone) of a block in a block-wise backlight unit

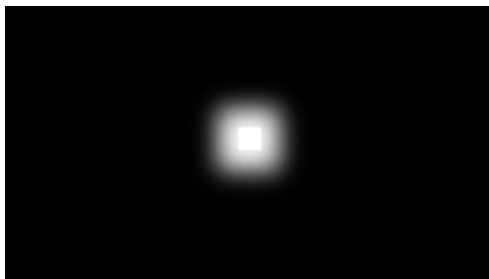

IEC

- b) Incoherent slightly-wide light spread function of a block in a block-wise backlight unit with slightly wide angular luminance cone compared to a)

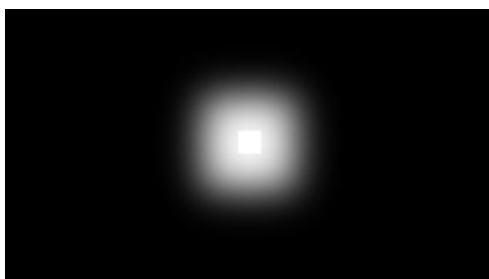

IEC

- c) Incoherent light spread function of a block in a block-wise backlight unit with wide angular luminance cone

NOTE The angular luminance cones are widening from a) to c).

Figure A.10 – Light spread functions of three BLUs with different optical structures

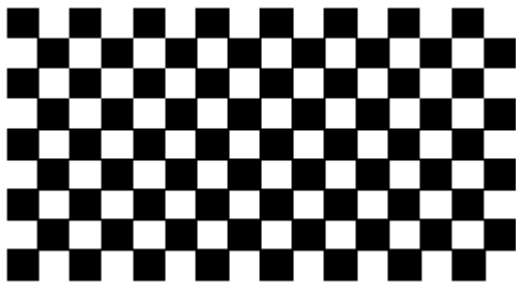

IEC

a) Checkerboard pattern (positive)

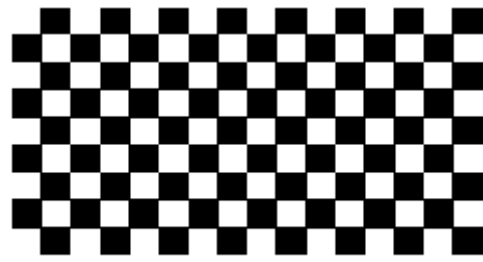

IEC

b) Checkerboard pattern (negative)

NOTE 1 Each block of the backlight unit is equal to the block of the checkerboard pattern. The crosstalk or optical S/N ratio can be evaluated by switching the blocks.

NOTE 2 The incoherent light spread function is used to evaluate the characteristics of a dynamic BLU and especially the leakage light from each block to the neighbouring blocks.

Figure A.11 – Checkerboard pattern for evaluation of the luminance uniformity in a BLU

INTERNATIONAL
ELECTROTECHNICAL
COMMISSION

3, rue de Varembé
PO Box 131
CH-1211 Geneva 20
Switzerland

Tel: + 41 22 919 02 11
Fax: + 41 22 919 03 00
info@iec.ch
www.iec.ch